



# BOWELL BH7 BACKHOE

For Medium Tractors With CAT I. & II. 3-Point-Hitch



- For 25 - 50 HP tractor
- Five optional buckets available from 230 to 900 mm width
- Optional grabber and hydraulic 360°turnable wood grabber



# BOWELL BH7 BACKHOE

Massive back hoe, designed for medium tractors up to 50 hp with CAT I. or CAT. II. 3-point hitch.



Tractor Mounted  
**BACKHOE**

**24 months**  
Warranty

12 months for commercial customers

€ from 3.298



The Bowell BH backhoes comply with all safety regulations and is CE tested following the 2006/42/EC machine directive.

Optional bucket widths from 230 to 900 mm and hydraulic 360° turnable wood grabber

**The Bowell BH-7 Backhoe is an affordable and high quality alternative to a mini excavator. The BH-7 is designed for medium to heavy duty performance and uses a very powerful hydraulic system creating a bucket digging force of 1,5to. The back hoe is easy to operate and is controlled by only two levers. The Bowell BH-7 can be mounted to all tractors with Cat I or Cat II three-point hitch.**

- 1** Maximum working depth 205 cm. Maximum working radius 295 cm.
- 2** Exchangable and hardened bushings for arm and feet for perfect service friendliness.
- 3** Hydraulic pipes with safety covers.
- 4** Safety valves for all control circuits.
- 5** Main hydraulics foot-safety-valve.
- 6** Hydraulic system with 4 additional connectors for new features like for example hydraulic 360° turnable wood grabber.



# Technical Specifications Bowell BH7 Backhoe

| DATA   | BH-7                         |
|--|------------------------------|
| Dimensions (HxWxD) (mounted on tractor)        | 180 x 155 x 122 cm           |
| Total weight                                   | 490 kg                       |
| 3-point hitch                                  | CAT I / CAT II               |
| Max. PTO shaft RPM                             | 540 RPM                      |
| Drive system                                   | PTO shaft pump               |
| Hydraulic tank                                 | 17 L                         |
| Hydraulic oil                                  | HLP32 oder HLP46             |
| Max. pump performance                          | 16 L/min at 2250 psi         |
| Tractor engine power recommended               | 25-50 HP / 18-37 kw          |
| Bucket dimension (LxWxD)                       | depending on selected bucket |
| Bucket volume                                  | depending on selected bucket |
| Max. working depth                             | 205 cm                       |
| Max. working radius                            | 295 cm                       |
| Max. height                                    | 310 cm                       |
| Max. unloading height                          | 180 cm                       |
| Max. liftable weight                           | 400 kg                       |
| Max. bucket digging force                      | 1500 kg                      |
| Backhoe turning angle                          | 180°                         |
| Bucket rotation                                | 172°                         |
| Hydraulic stabilizer width                     |                              |
| Up position / Down position                    | 119 cm / 217 cm              |
| Transport height / Transport depth / Transport | 180 cm / 122 cm / 119 cm     |
| Painting                                       | powder coated                |
| Metal crate (LxWxH)                            | 220 x 90 x 110 cm            |

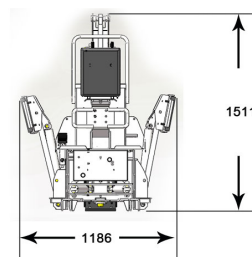
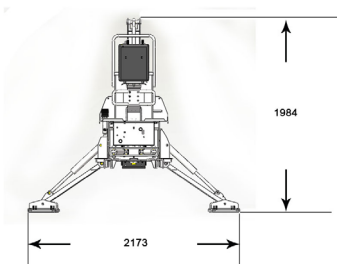
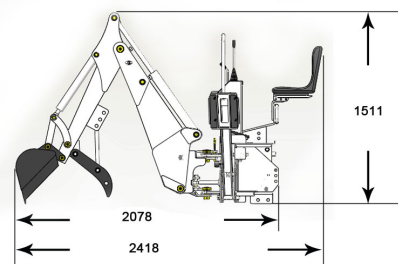
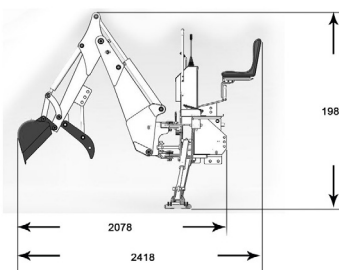
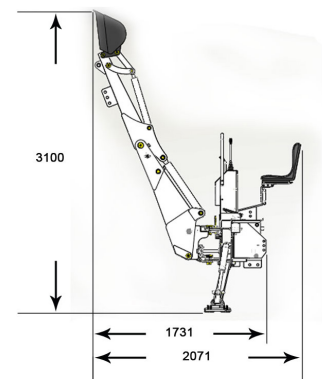
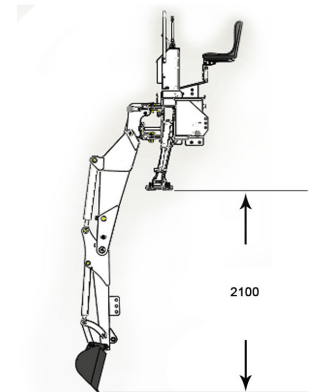
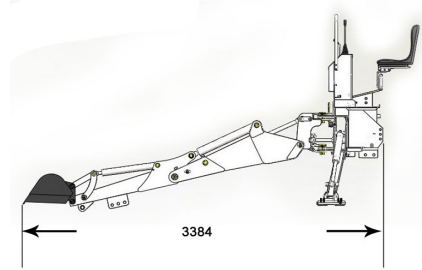



## ONLINE-SHOP FOR TRACTOR ATTACHMENTS

Flail Mower, Verge Mower, Power Sprayer, Boom Sprayer, Back Hoe and Snow Blades



### Contact

Telefon: + 49 (0) 4188 4444 773

E-mail: [info@bowell-tractor.com](mailto:info@bowell-tractor.com)

V&B Europe GmbH

Am Flidderberg 74

D-21256 Handeloh - Germany